

Belle Trace II HOA Compliance Standard for Trash and Storage Receptacles



Compliant Location



Non-compliant location



Observation point

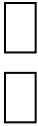

A/C Units



Sprinkler Features

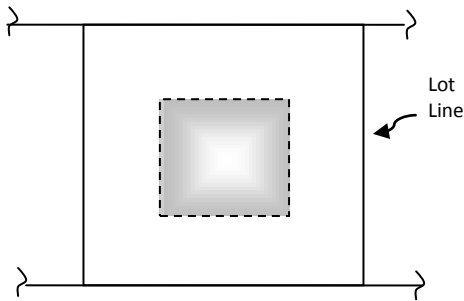

Meaning of Symbols

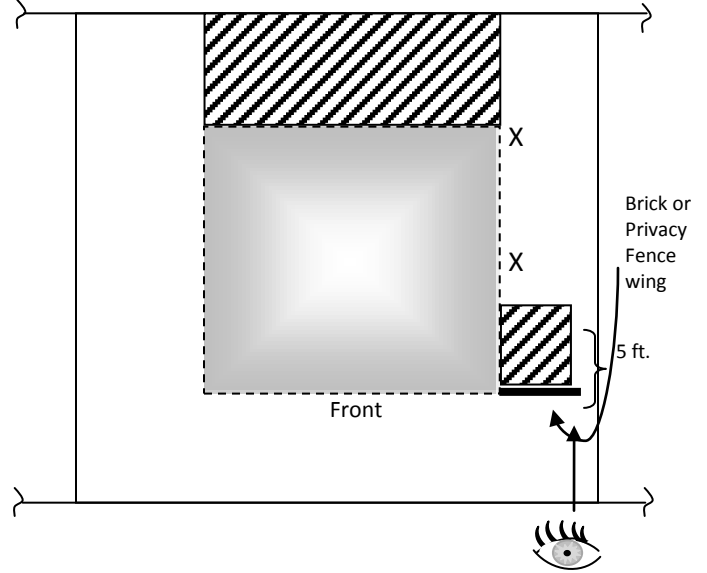

A wing of either brick or privacy fencing will create a compliant area 5 feet deep behind the wing. Storage receptacles should not stick up above the wing element. Homeowner should be compliant with building setbacks.

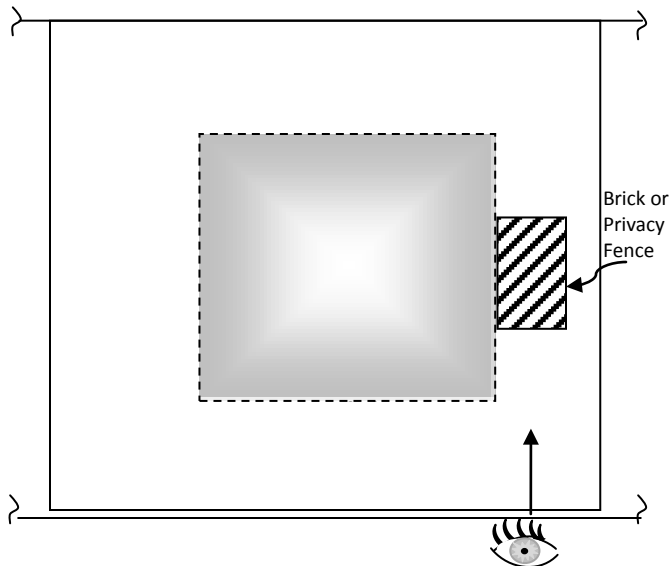

Some homes have fences or other features that hide AC units and plumbing features. Storage of trash receptacles or bins in these areas is compliant if not visible to the street.

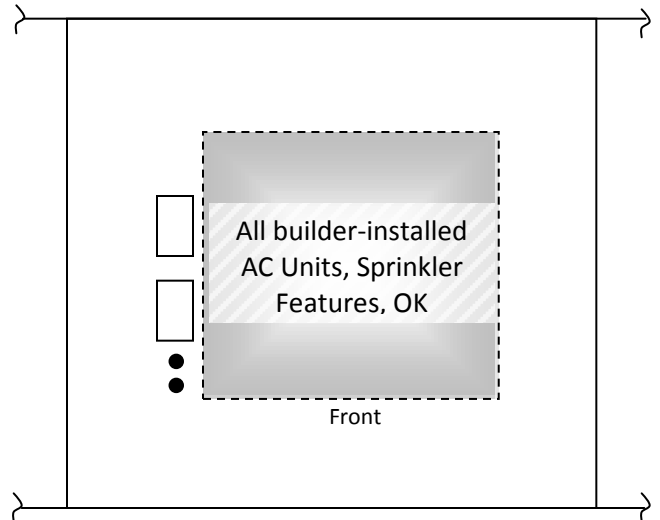

Most homes have visible AC units and plumbing features for sprinkler systems. The Homeowner is encouraged to cover sprinkler units.

(A) NO TRAILER, TENT, GARAGE, BARN, OUTBUILDING, NOR ANY STRUCTURE EXCEPT THAT ATTACHED TO THE HOUSE IS ALLOWED
 (B) NO ABOVE GROUND POOLS OF ANY TYPE
 (C) EXCEPT WHERE SPECIFICALLY AUTHORIZED BY THE DEVELOPER OR THE ARCHITECTURAL COMMITTEE IN WRITING, ALL RECREATIONAL OR PLAY STRUCTURES (OTHER THAN BASKETBALL GOALS) SHALL BE LOCATED BEHIND THE BACK BUILDING LINE OF THE RESIDENCE

Belle Trace II HOA Compliance Standard for Trash and Storage Receptacles

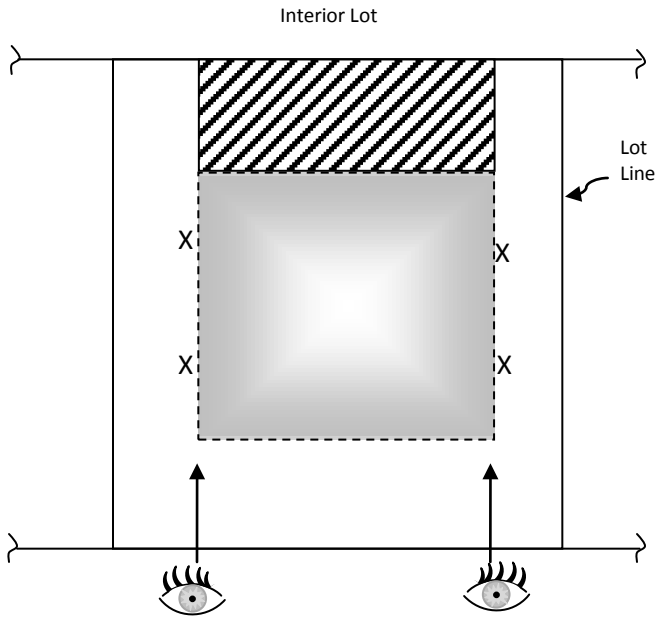

A home without a privacy fence will be compliant if an observer standing at the right or left corner at the curb cannot see visible storage bins, trash cans, or items not affixed to house.

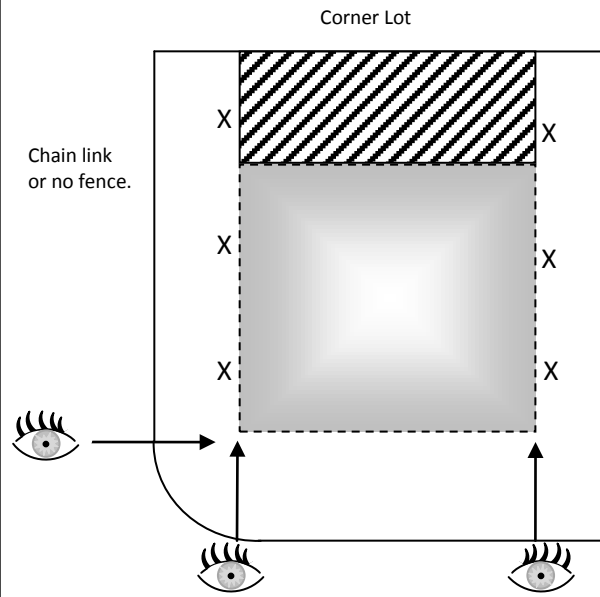

The HOA recommends you not place trash receptacles where they can be observed. Even though the back is visible, both street fronts need to be clear.

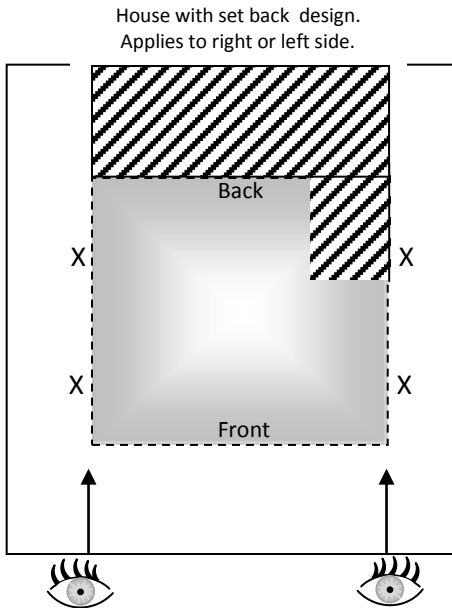

A home with setbacks as part of the house design will be compliant if an observer standing at the right or left corner at the curb cannot see visible storage bins, trash cans, or items not affixed to house.

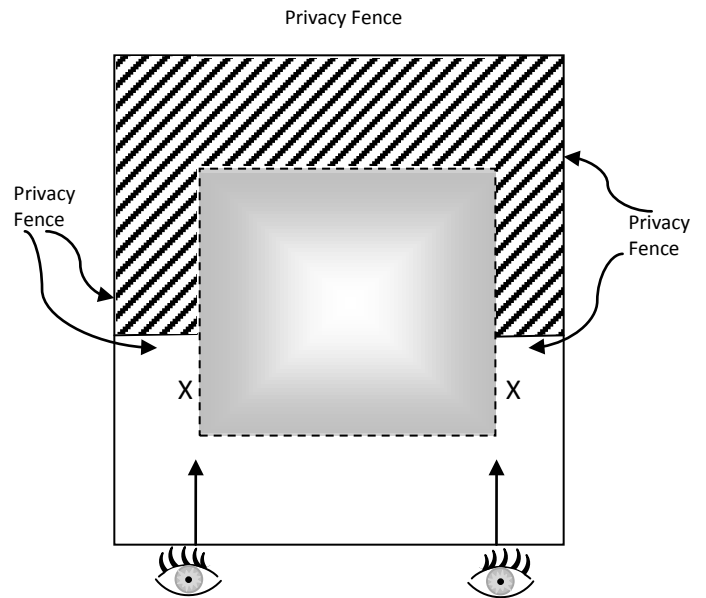

A home with a privacy fence as allowed by covenants will be compliant if an observer standing at the right or left corner at the curb cannot see visible storage bins, trash cans, or items not affixed to house.

(A) NO TRAILER, TENT, GARAGE, BARN, OUTBUILDING, NOR ANY STRUCTURE EXCEPT THAT ATTACHED TO THE HOUSE IS ALLOWED
 (B) NO ABOVE GROUND POOLS OF ANY TYPE
 (C) EXCEPT WHERE SPECIFICALLY AUTHORIZED BY THE DEVELOPER OR THE ARCHITECTURAL COMMITTEE IN WRITING, ALL RECREATIONAL OR PLAY STRUCTURES (OTHER THAN BASKETBALL GOALS) SHALL BE LOCATED BEHIND THE BACK BUILDING LINE OF THE RESIDENCE